



D OFFICE

PIONEERTOWN

MANE STREET OVERLAY

**LOESCHER
MEACHEM
ARCHITECTS**

1. INTRODUCTION & BACKGROUND

This document is intended to act as a tool for soliciting feedback during community discussions and forming a foundation for proposed development code amendments and Zoning Overlay to protect the National Historic Register Historic District designation for Pioneertown's Mane Street area and incorporate community feedback from workshops held as part of the creation of the Community Action Guide.

The effort to create an Overlay district for Pioneertown's Mane Street is the result of four major events: San Bernardino County's Countywide Plan work, the creation of the Pioneertown Mane Street National Register Historic District, ongoing frustrations by property owners and residents with existing county development code as it pertains to Mane Street, and increased tourism interest in Pioneertown.

Community Action Guide

In 2016, under the umbrella of a Countywide Plan update, San Bernardino County Planning, Pioneertown residents and community groups began a process to develop a community plan to document community interests, concerns, and ambitions to guide community action and inform future County policy. Two workshops, open to any Pioneertown resident, property owner, or business were held in late 2016. In 2018, the results of those meetings were published in draft form for public comment, ultimately resulting in their finalization in 2020 and incorporation in the Countywide Plan. This proposal seeks to propose code amendments and a Zoning Overlay on the intentions of that community input that respect those intentions and concerns.

Pioneertown Mane Street National Register Historic District

In 2017, in response to the lack of recognition for Pioneertown's contribution to the history of film, architecture, and culture, The Friends of Pioneertown, a 501(c)3 community non-profit, began gauging the interest among Mane Street property owners to obtaining formal historic status for Pioneertown. As San Bernardino County has no County mechanism for historic recognition, it quickly became apparent that any such effort could only be achieved at the State or Federal level. Working entirely with donated funds, the Friends of Pioneertown engaged a professional historian and began work with property owners and stakeholders to determine the scope and ambitions of a National Register Historic District nomination. In 2020, a nomination was submitted to the National Parks Service and California State Office of Historic Preservation for consideration. With significant support from local historians and without opposition, in June of 2020, Pioneertown was entered into the National Register of Historic Places as a Historic District, conveying special status and protections for the location, buildings, and environment, as well as creating some financial incentives for preservation and reuse. This proposal seeks to propose new regulations for Mane Street that allow modest and appropriate growth while incentivizing and lowering the barriers to reuse of existing structures, and preserving Pioneertown's character.

Resolution of Water Quality Issues

For nearly two decades, development in Pioneertown was primarily controlled not by the County Development Code, but by the absence of potable water. By 1999, the local water utility had fallen out of compliance with State and Federal water quality standards and was forced to impose a moratorium on new connections until the amount of fluoride, arsenic and uranium in the water could be brought under acceptable thresholds. That water meter moratorium effectively stopped all but scattered single family residential construction in Pioneertown, retarding growth and inadvertently preserving community character and structures which would later be recognized in the National Register

designation for Mane Street. With the help of State and Federal Funds, in late 2019 a pipeline was completed finally delivering potable water to the Pioneertown Community. It is expected that in early 2021 the moratorium on new water meters will be lifted, opening metaphorical flood gates for development that current regulation is ill-suited to manage. This proposal seeks to create appropriate regulations for development and construction to ensure that new developments enabled by the sudden availability of water are community appropriate, of reasonable scale, and do not threaten the quality of life of residents.

Frustrations with County Land-Use Regulation as it pertains to Mane Street

Pioneertown's Mane Street area has been zoned "SD-RES", a designation which favors single-family residential uses and imposes high barriers on commercial uses. At some point in history, previously commercial buildings and land uses were redesignated as single-family residences without sufficient community engagement. The result has been that many of Mane Street's historic commercial buildings (including at one time the Red Dog Saloon, Pioneer Bowl, Saddlery, and Post Office) were erroneously categorized as residences, effectively preventing their commercial use unless the property owners were to undertake a costly (>\$80,000) discretionary approval process to obtain Minor Use or Conditional Use permits. With the exception of the Red Dog Saloon, no property owner in over twenty years has been successful in obtaining county approvals to reuse these structures commercially. Additionally, owners of long-existing and continuing uses (most notably the Pioneertown Corrals) have received Notices of Violation from County Code Enforcement with orders to cease operation. While the State of California allows property owners to use the California Historic Building Code to allow additional flexibility in the reuse, preservation and improvement of historic structures, San Bernardino County's development code does not recognize any special status for historic buildings, and their re-use, improvement, and rehabilitation is held to the same standard as new construction, standards which can be financially infeasible and sometimes impossible to meet.

Due to the Historic District designation and contact with County staff for the Countywide Plan, Pioneertown residents and businesses have started a conversation with the Land Use Services Department and the Planning, Building and Safety, Land Development and Code Enforcement Divisions. The County will review and adopt development code amendments and Zoning Overlays proposed by communities. Therefore, these code amendments and overlay are proposed to lower the barriers for reuse, adaptation, and preservation of historic structures, and to support an appropriate balance of community and tourism interests and protect the Historic District designation.

Increased Tourism Interest in Pioneertown

Tourism interest in Pioneertown has largely mirrored the meteoric increased visitation to nearby Joshua Tree National Park. In the eight years beginning in 2011, annual Park visitation increased from 1.4M visitors per year to over 2.9M in 2019. Since 2016, Pioneertown has been featured as a travel destination in national newspapers such as the New York Times, Wall Street Journal, Washington Post, and Chicago Tribune, travel magazines such as Conde Nast Traveller and Sunset Magazine, and lifestyle publications such as Dwell, Wallpaper, and Los Angeles Magazine.

These additional visitors have increased interest and awareness in Pioneertown (a positive), but also created a situation where existing infrastructure and building regulation has not been revised to accommodate (or mitigate) that interest and impact. With increasing visitation comes increased interest from outside development interests in capitalizing on tourism -- current land use regulation is entirely inadequate in its ability to manage growth appropriately. This proposal seeks to provide a framework which can manage and accommodate appropriate tourism uses while maintaining community character and preventing out-of-scale development.

2. OBJECTIVES

This proposal takes as its guide the intentions of the Pioneertown community as expressed in the Countywide Plan workshops and Community Action Guide that documented those intentions. While the Community Action Guide addressed multiple subjects (not all of which can be addressed via an Overlay) those specifically related to land use can and should be incorporated into revised zoning. The Community Action Guide objectives and aspirations addressed by this proposed Overlay are as follows (commentary on how these objectives and aspirations are addressed in the proposed Overlay follow in *italics*):

“Aspiration Statement 1: A Preserved Old West Setting

Pioneertown’s storied Old West-Hollywood past has left an indelible mark on the community, particularly characterized by the building facades along Mane Street and the ingrained western riding culture found within the community. Although the community is forward thinking, the Old West culture that has historically embodied Pioneertown remains uncompromised.”

Commentary: The goals of this Aspiration Statement are met by multiple aspects of the proposed Overlay, most notably the Design Standards.

“Aspiration Statement 3: Balanced Growth and a Viable Town Center around Mane Street

There is a delicate balance between expanding business opportunities in Pioneertown Communities and maintaining the rural desert lifestyle that residents of the community value. The community’s approach to responsible development that is primarily focused in the town center along Mane Street has achieved that equilibrium. Independent businesses that conveniently provide goods and services for the local community, while supporting sustainable tourism, have established themselves. These businesses have given the town center vibrancy and provide local jobs and additional tax revenue. The new investment in the area has also led to a restoration of the original buildings on Mane Street.”

Commentary: Although there has been renewed interest in Pioneertown, challenging Land Use policies have prevented the restoration and reuse of many of its historic structures, including the Pioneer Bowl, Sound Stage, and White’s Grocery. This proposed overlay will lower the barriers to the reuse of these structures, and provides Design Standards and modified Use Tables which should allow modest growth while also ensuring that Pioneertown’s scale and character are preserved.

“Action Statement A.1: Preserve and restore original buildings in the community”

Commentary: This Action Statement is addressed in the Design Standards which simplify the process for obtaining Planning approvals for the reuse of historic structures within the Overlay district, and which ties the requirements for alterations of historic structures to national recognized best practices which dovetail with federal tax incentives for preservation.

“Action Statement A.2: Collaborate with the County to maintain the Old West theme of the community by creating architectural design guidelines for new construction.”

Commentary: This Action Statement is addressed in the Design Standards which will ensure that new construction and alterations are of compatible scale and materials.

“Action Statement A.3: Keep dirt roads in the community.”

Commentary: This Action Statement is addressed in the Design Standards which will preserve dirt roads throughout the Overlay district.

“Action Statement A.6: Protect residential equestrian uses that are part of the Old West heritage.”

This Action Statement is addressed in the Use Table which lowers barriers to equestrian uses on Mane Street, and requires installation of hitching rails when uses are created or expanded.

“Action Statement A.7: Protect, maintain, and expand open spaces in the community.”

This Action Statement is addressed in the proposed Minimum Lot Size, Lot Coverage, and FAR requirements which in combination serve to ensure that new development maintains an appropriate amount of open space and preserves Pioneertown’s character.

“Action Statement B.1: Advocate with the County to establish a commercial zoning overlay on Mane Street that restricts big box retail, encourages neighborhood commercial scale retail and lodging, and establishes flexibility for locally-grown businesses.”

This Action Statement is addressed directly by this proposed Overlay language and revised Use table.

“Action Statement B.2: Provide public restroom facilities on Mane Street and explore local funding options for design and construction.”

While an Overlay cannot compel or directly cause the construction of public restrooms (particularly since no publicly owned land exists within the district) this Action Statement is addressed by the proposed Use Table which lowers the barrier to Planning Approval of public restroom facilities by a private individual or entity (including a non-profit).

“Action Statement C.1: Prepare a traffic and parking plan to better manage traffic and parking issues due to visitors and tourists.”

This Action Statement is partially addressed by the Overlay by District Parking (which encourages the use of centralized/shared facilities), standards governing the location of parking, and by the Temporary Special Event Permit provisions which require off-site parking and shuttles for major events (none are currently required).

3. APPLICATION & ENFORCEMENT

The proposed Overlay is intended to serve as a supplement and replacement (where required) to the provisions of the San Bernardino County Development Code. As such, it applies only to new and modified uses and buildings, and is to be administered as part of the ordinary planning review process by County Staff or outside consultants. No aspect of this proposal includes the creation of a citizen or local review board for purposes of determining a project's compliance with the provisions of the Overlay.

4. BOUNDARIES

The boundaries of the proposed Overlay coincides with the parcels identified as subjects for commercial zoning by the County of San Bernardino as part of the Countywide Plan and noted as eligible for designation within an Overlay. These parcels include those immediately to the North and South of Mane Street bounded by Tom Mix Road at the West and Curtis Road at the East, with the addition of "The Desert Willow Ranch" east of Curtis which has historically had residential uses but a commercial zoning designation (SD-COM) for reasons that are not known. Excluded from the district are non-commercial properties to the North of Rawhide Road, non-commercial properties to the South of Pioneertown Road, and the "OK Corral" property to the west of Tom Mix Road. (See *Figure 1* below, red toned areas indicate properties within the proposed Overlay boundary).

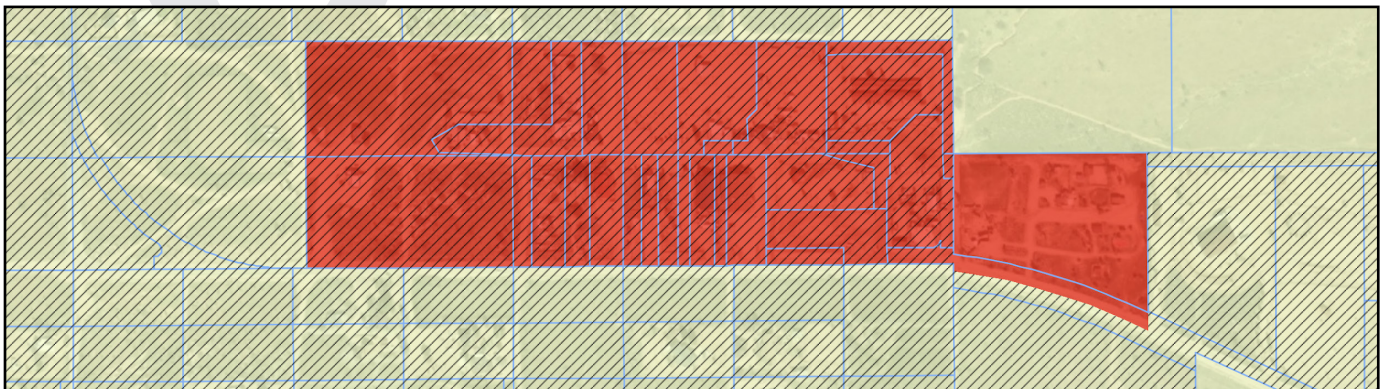

Figure 1

5. PROPOSED OVERLAY SCOPE

Based on guidance from County Staff, a Tourism Overlay may be created under the following conditions:

The Tourism Overlay allows a recognized area to customize development standards that are designed to enhance the tourist experience and create areas where people want to visit and return to over time.

Aside from those Tourism Overlay components listed below, all requirements of the Development Code and the Building and Safety codes shall be complied with in full.

This proposal intends to modestly expand these objectives to equally address resident and community harmony, and to preserve and revitalize Pioneertown's existing historical structures. Based on guidance from staff, some aspects of community concern (Short Term Rentals, Native Plants, Dark Sky Ordinance) are not to be addressed as part of an Overlay proposal (in each of these cases, the County of San Bernardino is currently entertaining updated regulations outside of the Overlay process).

The Overlay applies to the Development Code only, and has no bearing on other ordinances, policies and regulations that impact and restrict land-use in Pioneertown. Some examples of these regulations and policies unaffected by the Overlay include:

- Building Codes as adopted by San Bernardino County (these include the California Building Code, California Residential Code, California Historic Building Code, etc.)
- California and Federal Disabled Access requirements (including the Americans with Disabilities Act)
- San Bernardino Department of Environmental Health Services regulations and policies. Most notable among these is the Local Area Management Plan (LAMP), which regulates sewage and wastewater disposal, and significantly restricts land development in areas not served by municipal sewer systems.
- County of San Bernardino Special Districts policies for the provision and apportioning of potable water and new meters.

6. PROPOSED OVERLAY SCOPE

Among zoning code regulations, the provisions that govern lot size, height, coverage, floor area ratio, and setbacks are among the most important in determining the form and feel of developed spaces. Current requirements prevent the construction of buildings compatible with Mane Street’s character by imposing setbacks that push building fronts well behind existing structures. The Overlay proposes to modify the setback and height requirements to allow new structures to align with the prevailing Mane Street building frontages, and to prevent three-story structures. The proposed requirements follow (commentary for each item is shown in italics):

Table 1 – Proposed Development Standards

Development Feature	Requirement	Commentary
Maximum Density	1 unit per 40 acres	<i>Unchanged from SD-RES</i>
Setbacks		
Mane Street	0 feet - Must maintain prevailing setback	<i>Reduced to allow prevailing setbacks to remain. SD-RES currently requires 25 foot front yard setbacks. [Figure 2]</i>
Front (Parcels not fronting on Mane Street)	25 feet	<i>Only applies to the Desert Willow Ranch parcel and one anomalous parcel near Roy Rogers Road. Requirements are unchanged from SD-RES.</i>
Side Street (Public or Private)	0 feet	<i>Reduced to allow prevailing setbacks to remain. Current SD-RES standards require 10 foot side yard setbacks.</i>
Side (Interior)	10 feet	<i>Unchanged from SD-RES</i>
Rear	25 feet	<i>Unchanged from SD-RES</i>

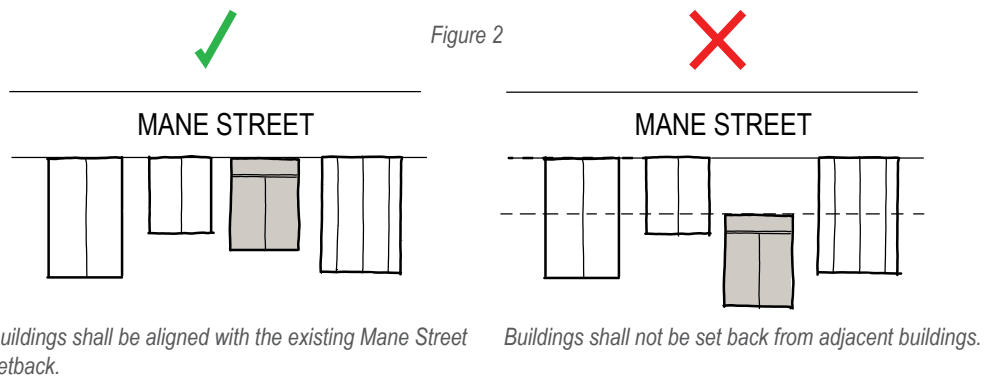

Floor Area Ratio (Maximum), Parcels under 1 Acre	0.15:1.0	<i>Reduced from SD-RES to ensure that new construction maintains an appropriate density [Figure 3]</i>
Floor Area Ratio (Maximum), Parcels 1 Acre or larger	0.10:1.0	<i>Reduced from SD-RES to ensure that new construction maintains an appropriate density [Figure 4]</i>

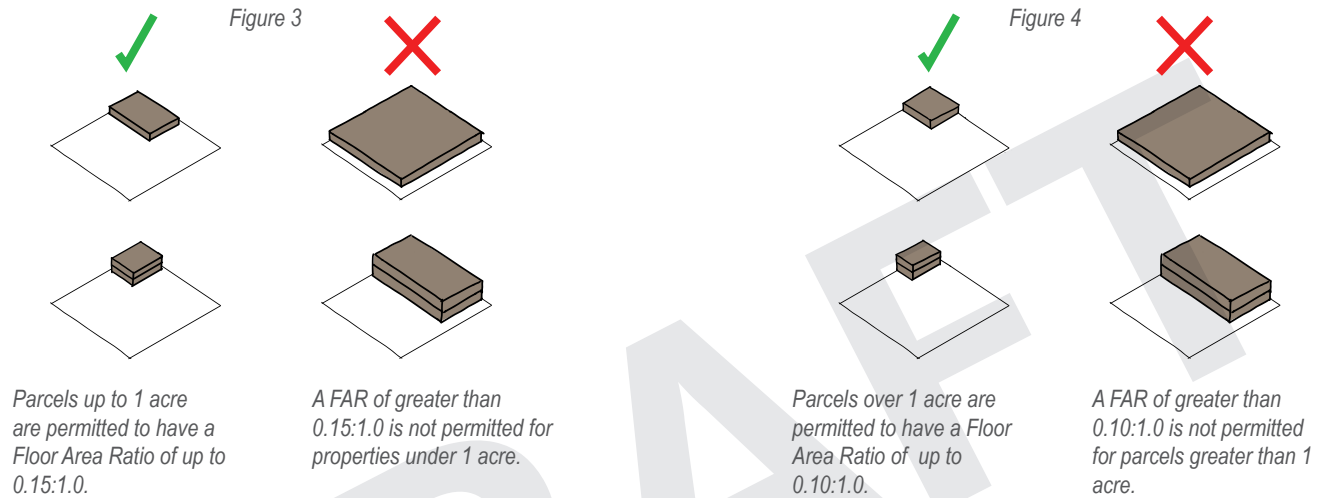

Maximum Coverage, Parcels under 1 Acre	60%	<i>Reduced from SD-RES (80%) to ensure that new construction maintains an appropriate density [Figure 5]</i>
Maximum Coverage, Parcels 1 Acre or larger	40%	<i>Reduced from SD-RES (80%) to ensure that new construction maintains an appropriate density [Figure 6]</i>

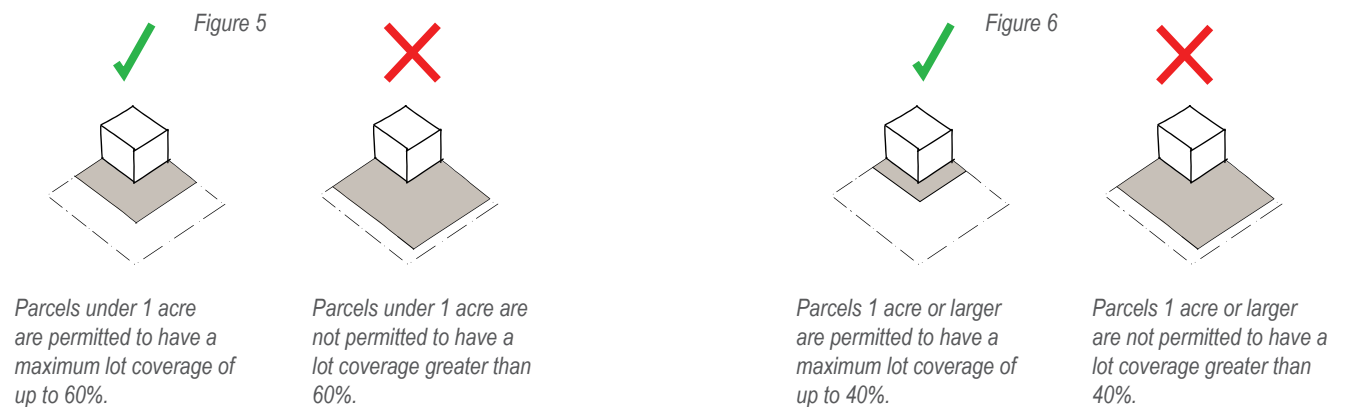

Height Limit	22 feet	Reduced from 35 feet to match the height of the Sound Stage (precise height to be confirmed) [Figure 7]
--------------	---------	---

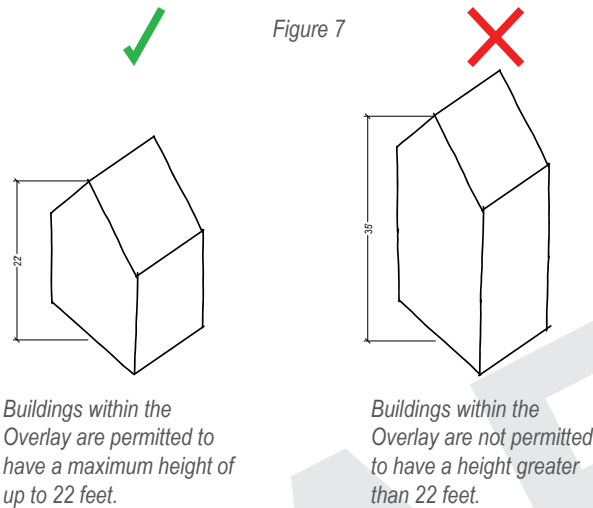

7. PROPOSED REQUIREMENTS FOR DEDICATIONS AND ROAD IMPROVEMENTS

The San Bernardino County Development Code stipulates that road improvements and dedications must be granted as conditions of approval for new developments (both commercial and residential). As written, these would have significant deleterious impacts on the character and experience of Pioneertown by requiring the installation of paved roads, and expropriating property from property owners. The following modifications are proposed:

Proposal: Dedications

No expansion of existing Street or Highway dedications shall be required

Commentary: Absent this modification, County standards require 44'-0" half-width dedications at section lines and quarter section lines, and 30'-0" dedications at sixteenth section lines. Half and quarter section lines occur within the district at Mane Street in the East-West direction, and Roy Rogers and Curtis in the North-South direction. Additionally, eight quarter-section lines exist in the North-South direction, which would require property owners to cede land for County use, dramatically decreasing parcel area of properties such as the Pioneertown Corrals, Pioneer Bowl, Likker Barn/Pappy's Parking Lot, Red Dog Saloon/Rancho Burrito, and FHR properties for no obvious beneficial purpose.

Proposal: Required Road Improvements

The following improvements shall not be required within the Overlay district:

1. Installation of sidewalks
2. Installation of concrete driveway approaches
3. Paving

Where required, new developments may be required to install drainage structures or grading to ensure that road surfaces remain serviceable.

Commentary: Action Statement A.3 notes “keep dirt roads within the community” an aspiration not currently possible without modification of the Development code or an overriding provision within the Overlay.

Table 2 – Lot Size

Lot Dimensions					
Minimum Lot Area	Maximum Lot Area	Minimum Width	Minimum Depth	Maximum Width to Depth Ratio	Commentary
2 acres	5 acres	60 feet	100 feet	1:3	<i>Unchanged from SD-RES, except Maximum Lot Area (new)</i>

8. PROPOSED PARKING AND CIRCULATION STANDARDS

Although the Overlay program allows the modification or reduction of parking requirements to be considered, no deviation from San Bernardino County parking quantity standards is proposed here. While San Bernardino County’s parking requirements are conservative relative to other jurisdictions, Pioneertown is in a rural environment unserved by public or alternative transportation, and existing relatively high parking requirement ratios appear to be justified. With that being said, the following modifications to the County’s parking standards are proposed:

Proposal: District Parking

When parking for new buildings and/or use intensifications or changes of use results in additional parking requirements that cannot be accommodated on-site, such parking may be partly or entirely provided off-site within a parking facility located within the District subject to Site Plan approval and formalization of the off-site parking agreement via a mechanism acceptable to the County (such as a recorded covenant or agreement).

Commentary: District parking schemes allow willing property owners to provide required parking “off-site” (on a parcel other than the one where the Use generating the parking requirement is located). This has been successfully been done in many jurisdictions and allows the parking to be provided in a more flexible and efficient manner. This is particularly appropriate in the Mane Street district where pedestrian activity is encouraged.

Proposal: Parking Location

Parking shall be located behind structures, and shall be screened from Mane Street and Pioneertown Road via site walls and vegetation. [Figure 8]

Commentary: Current parking standards encourage parking to be required at the front of structures resulting in a condition where parking lots will be sited within the Mane Street viewshed. This provision places parking behind structures which is both closer to vehicular access roads (Pioneertown Road, Rawhide Road) as well as screening cars from the Mane Street historic viewshed.

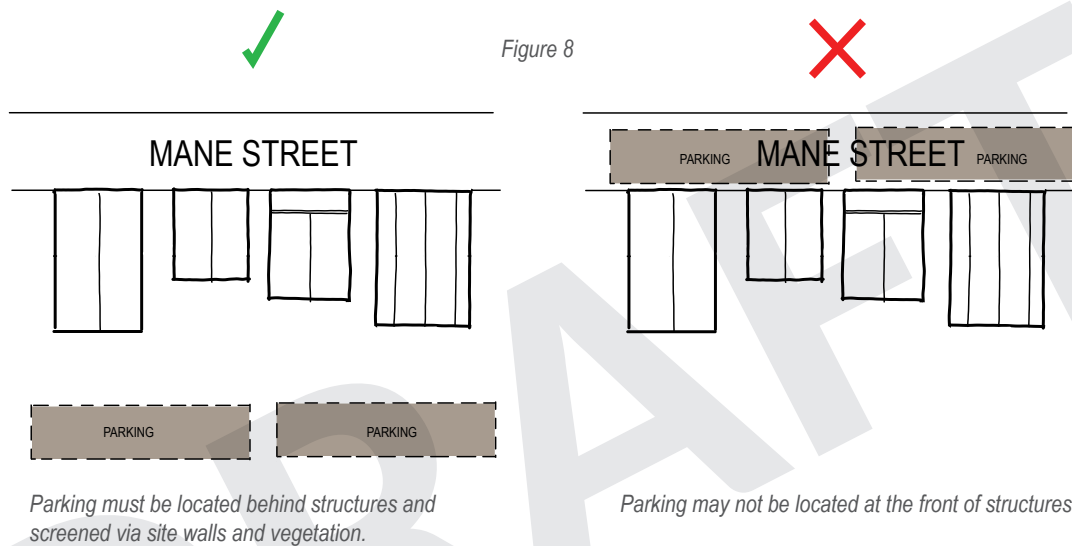

Proposal: Driveways

Driveways for vehicle ingress and egress shall not be located on the Mane Street frontage of any parcel.

Commentary: This is consistent with other features protecting the Mane Street historic viewshed and locating principal vehicle circulation off of Mane Street.

Proposal: Paving and Materials

Public roads and private roads shall be unpaved and dirt except as required for fire apparatus access, where polymer-stabilized soil mixes which retain the historic dirt aesthetic while meeting SBC Fire “all weather surface” requirements may be used. Parking lots shall be unpaved except in those areas required to comply with disabled access provisions.

Commentary: Current County Standards require roads to be paved as part of the approvals for new developments. This provision allows dirt roads to be maintained in keeping with the Historic District character defining features and Action Statement A.3.

9. PROPOSED USE MODIFICATIONS

Use Tables define the types of businesses and functions that are allowable, and under the County review mechanism they may be considered and approved. The proposed use table (Section 12) simplifies the process for new community-serving businesses (farmers markets, grocery/convenience stores, small retail), prohibits new non-compatible uses (chain stores, large retail, wind-energy systems, gas stations) and lowers the requirements for small scale, compatible tourism uses (small motels, hotels, restaurants, bars) and raises the requirements or prohibits high-intensity or incompatible uses (night clubs, large developments). The preservation and re-use of historic structure is incentivized by providing them with an easier path to approval than new developments and construction -- structures noted as "Contributing" Structures to the Mane Street Historic District per the National Register nomination shall allowed a lower level of review to incentivize their re-use and restoration. If a Site Plan Review is insufficient, a new review level may need to be introduced.

The following Uses and definitions are new to the Development Code as part of the proposed Overlay:

Franchise business: All businesses in the retail trade, accommodation and food services, and other services as defined in the North American Industrial Classification System (NAICS), that have 2 or more establishments worldwide under the same trademark, service mark, or company brand name, regardless of ownership. Such establishments maintain two or more of the following features: a standardized array of merchandise, a standardized facade, a standardized decor and color scheme, uniform apparel, standardized signage, a trademark or a service mark.

Commentary: This is in response to Action Statement B.1. The proposed Use Table prohibits Franchise Businesses within the district.

Outdoor Dining, Accessory: The use of an outside area by a food establishment on the same or adjacent parcel to accommodate the same eating and drinking activities that occur within the establishment and shall not include amplified music, live music, performances or events (see Sports or Entertainment Assembly) except as an approved Temporary Use. Accessory Outdoor Dining areas shall not exceed the larger of the floor area of the associated indoor dining floor area, or 750 square feet.

Commentary: Outdoor dining allows businesses to seasonally expand their service footprint to meet tourism demand without requiring new construction or architectural changes to the Mane Street viewshed. The use of newly established outdoor dining facilities for concerts is prohibited except under a Temporary Special Event Permit.

Public Restroom Facility: Any structure or facility situated on public or private property equipped with toilets, urinals or washbowls, or other similar facilities, erected and maintained for use by members of the general public for personal hygiene and comfort.

Commentary: This is to simplify the planning regulations related to property owners providing public restrooms facilities on their property. See Action Statement B.2.

The following Uses and definitions are modified from the the Development Code as part of the proposed Overlay:

Camp or Campground: A site used or intended for use for temporary occupancy by campers providing their own tents, trailers, or vehicles as shelter, which may include individual campsites, but where utility hookups for recreational vehicles are typically not provided.

Commentary: This is to clarify that “Campgrounds” are those types of accommodations where guests provide their own shelter. In cases where shelter is provided by the property owner or operator, the use shall be considered a Motel (see below)

Motel: A building or group of two or more detached, semi-detached or attached buildings or shelters containing guest rooms designed, used and intended, wholly or in part, for the accommodation of transients for compensation on a daily or weekly basis. These establishments provide lodging and parking for automobile travelers and the rooms are usually accessible from outdoor parking areas. These establishments may include guest rooms with food preparation areas (kitchenettes) and are designed, intended or used primarily for the accommodation of automobile travelers. Included are lodging establishments designated as tents, trailers cabins, motor courts, and similar designations provided by the proprietor; not including those facilities defined in residential care facilities or any jail, hospital, asylum, sanitarium, orphanage, prison or other building in which human beings are housed and detained under legal restraint.

Commentary: This is to clarify that “Motels” are those types of accommodations where hosts or operators provide shelter for guests (see Campground, above).

Floor Area: The area included within the surrounding exterior walls of a building or portion thereof, exclusive of vent shafts and courts. The floor area of a building, or portion thereof, not provided with surrounding exterior walls shall be the usable area under the horizontal projection of the roof or floor above.

Commentary: “Floor Area”, is a term which is used by the Development Code but not defined. The proposed definition above is the same as that used by the California Building Code.

10. SITE AND BUILDING DESIGN STANDARDS

The Overlay proposes to establish architectural standards for the material, massing, and form of structures within the district in accordance with Action Statement A.2: “Collaborate with the County to maintain the Old West theme of the community by creating architectural design guidelines for new construction.” The standards that follow are derived from the Character Defining Features as set forth in the Mane Street National Historic Register documentation. Utilizing these features will ensure protection of the Historic District designation.

Alterations and Additions

Alterations and Additions to historically contributing structures, elements, and features shall be performed in accordance with the Secretary of Interior’s Standards for Rehabilitation.

Commentary: The Secretary of Interior’s Standards for Rehabilitation are time-tested and consensus-based guidance for the alteration and repair of historic structures, and used as the criteria for rehabilitation tax incentives and California Environmental Quality Act impact evaluation.

Building Massing

No building or structure shall exceed the following limits:

1. Mane Street Fronting Dimension: 70'-0", maximum [Figure 9]
2. Building Area (Total): 7,000 SF, maximum [Figure 10]

Commentary: These limits are based on the Pioneer Bowl, Mane Street's largest structure.

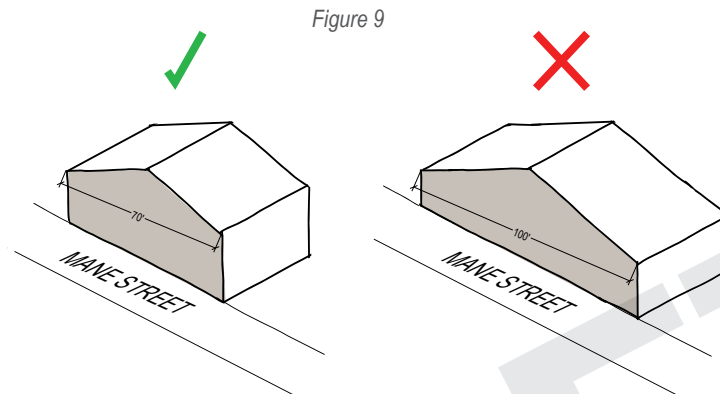

Mane Street-fronting buildings are permitted to have a maximum frontage dimension of 70'-0".

Mane Street-fronting buildings are not permitted to have a maximum frontage dimension greater than 70'-0".

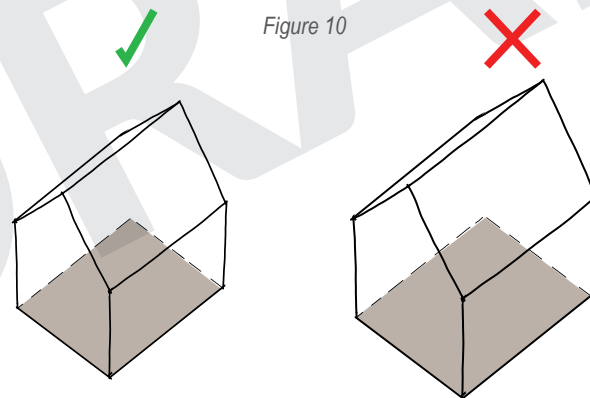

Buildings with a total square footage of 7,000 or less are permitted within the overlay.

Buildings with a total square footage greater than 7,000 are not permitted within the overlay.

Building Location and Orientation

For parcels abutting Mane Street, Primary structures shall front on Mane Street and be aligned with the prevailing setback. The pedestrian entrance and perceived front of all new structures shall be facing onto Mane Street.

For parcels not abutting Mane Street, ordinary Development Code provisions shall apply.

When a parcel has multiple buildings or structures, a Mane Street separation distance based on building size shall be established as follows:

Table 3 – Building Separation Requirements

Building or Structure Size	Mane Street Frontage Building Separation
Less than 1,000 SF	5 feet
1,001 - 2,000 SF	10 feet
2,001- 3,000 SF	15 feet
3,001-4,000 SF	20 feet
4,001-5,000 SF	25 feet
5,001 - 6,000 SF	30 feet
Greater than 6,000 SF	35 feet

Commentary: These provisions allow reasonable development along Mane Street while ensuring that when multiple new buildings are added to a single parcel that the massing and scale remains compatible with the Mane Street district historic guidelines. [Figure 11]

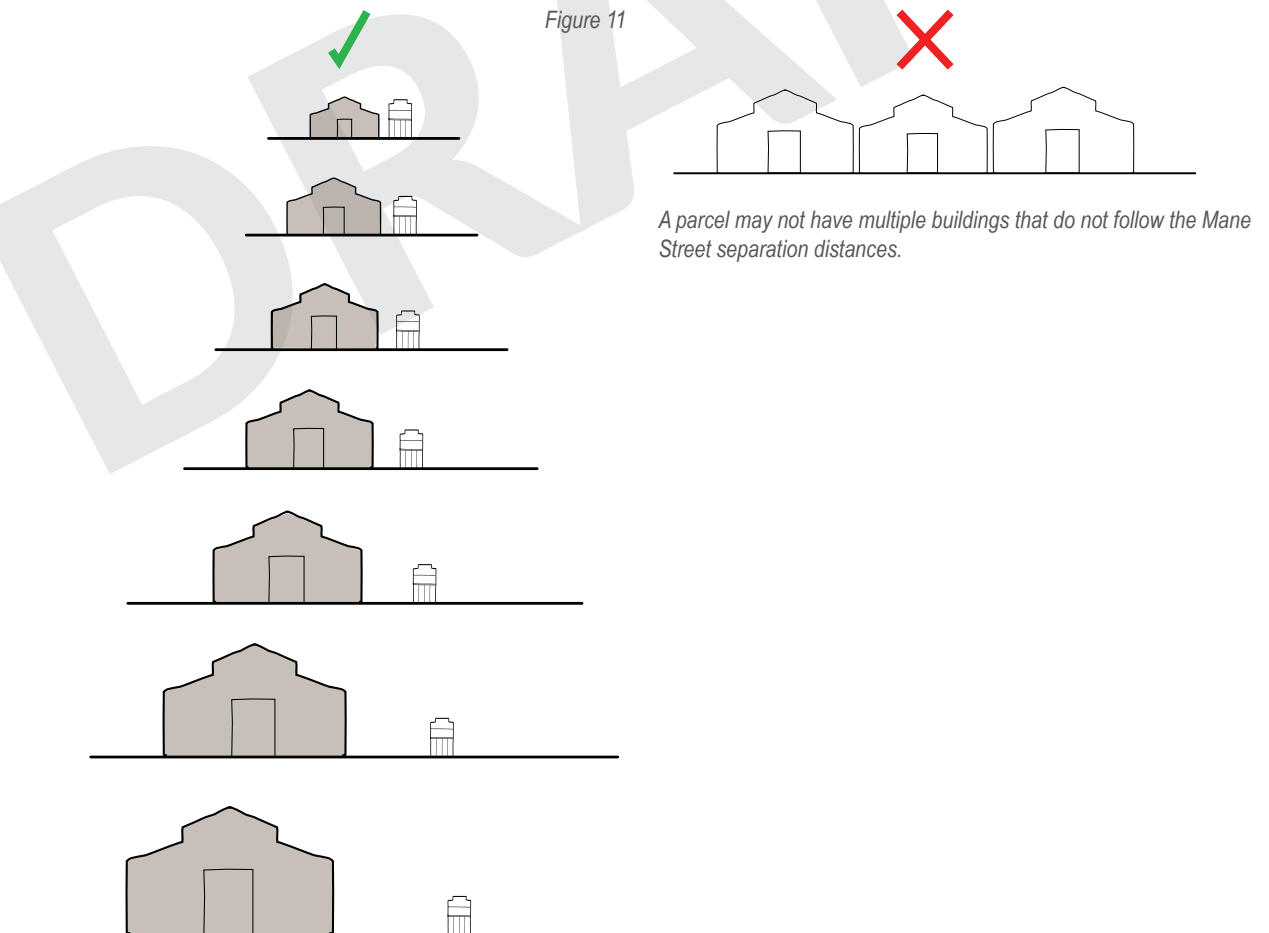

Figure 11

A parcel may not have multiple buildings that do not follow the Mane Street separation distances.

When a parcel has multiple buildings, a Mane Street separation distance is required based on building size.

Accessory Structures and Uses (as defined by the Development Code) shall align with the prevailing Mane Street setback, or shall be located behind primary structures. [Figure 12]

Commentary: With the exception of Pappy and Harriet's and the Pioneertown Motel, all Mane Street structures align with the prevailing setback.

Figure 12

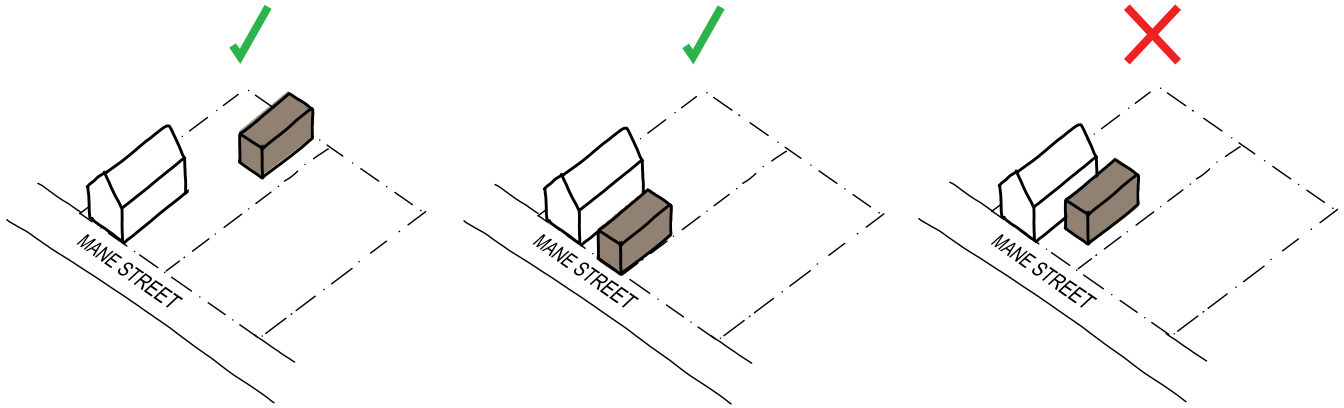

Accessory structures may be located behind primary structures.

Accessory structures may align with the prevailing Mane Street setback.

Accessory structures may not be located next to, but not aligned, with the prevailing Mane Street setback.

Building Form:

The form of all new buildings shall be based upon one of the following Typologies [Figure 13]:

1. Barn Subtype
2. Cabin Subtype
3. False Front Western Commercial Subtype

Figure 13

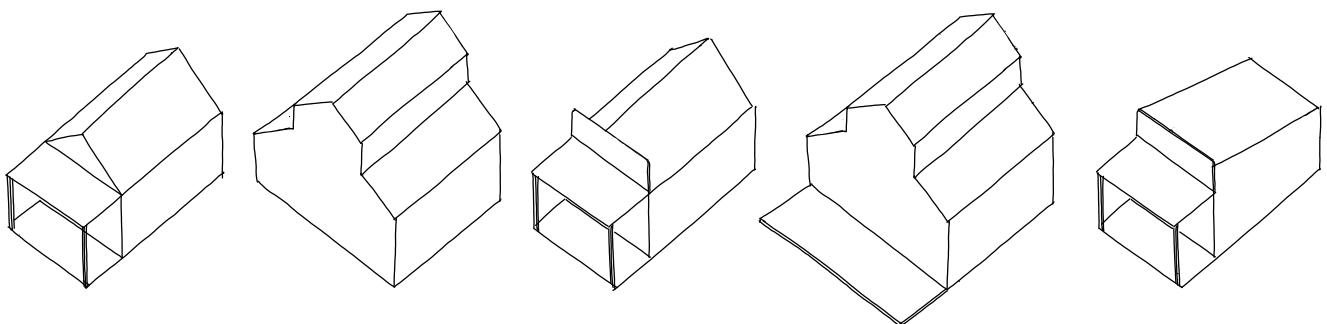

Cabin subtype

Barn subtype

False front western commercial subtype

Barn subtype with front deck

Cabin subtype with shed roof

Building Materials

Buildings elevations within the district may have the following finishes:

1. Wood siding (shiplap or board and batten)
2. Railroad ties
3. Adobe brick
4. Stucco
5. Corrugated metal (side and rear elevations only)

Windows within the district shall have divided lites and shall be constructed of the following materials:

1. Wood (painted or unpainted)
2. Steel

Roofing

Roof types within the district shall be one of the following types:

1. Gabled
2. Shed
3. Low-slope (where concealed by false-fronts or parapets)

Roof materials within the district shall be of the following materials:

1. Metal
2. Asphalt Shingle
3. Asphalt Roll Roofing
4. Wood shake
5. Roof material is unrestricted in conditions where the roof surface is concealed by parapets or false fronts.

Porches and Railings

Porches and decks shall be constructed of the following materials:

1. Wood, dimensional (unpainted)
2. Concrete

Railings, handrails and guardrails shall be constructed of the following materials:

1. Wood (unpainted)
2. Steel pipe, painted
3. Fences and Site Walls:

Fences and Site Walls

Site Walls within the district shall be constructed of the following materials:

1. Adobe Brick

Fences in the district shall be constructed of the following materials:

1. Wood, dimensional (unpainted)

Vegetation

Landscape plant materials within the district shall be plants native to the Morongo Basin. (Reference the California Native Plant Society inventory for zip code 92268 on www.calscape.org)

New or expanded developments shall maintain existing Joshua Trees in place.

Commentary: Native plants, (and Joshua Trees in particular) are Character Defining Features of the Mane Street Historic District. Based on this fact, as well as recent California Department of Fish and Wildlife work which has determined that the Western Joshua Tree is eligible for listing as a Threatened Species, no relocation or removal of Joshua Trees shall be permitted.

Signage

Signage within the district shall be constructed of the following materials:

1. Wood, dimensional (painted)
2. Neon

Signage not visible from Mane Street may be constructed of the following additional materials:

1. Painted Metal
2. Internally illuminated plastic box signs

See Table 4 for On-Site Signage requirements.

Roads and Parking Lots

Roads and parking lots within the district shall be unpaved dirt without gutters. Paving is permitted to the extent it is required for disabled access compliance.

For all new or expanded uses, 10'-0" lineal feet of hitching rail for equestrian use shall be provided for every 25 required parking spaces (or fraction thereof).

Table 4 – On-site Signs

Type of Sign	Individual Business/Structure Not a Part of a Complex	Multi-Tenant Complex			Occupant within a Multi-Tenant Complex	
Freestanding						
	''	Proposed	SD-RES	Proposed	SD-RES	Proposed
Pole or Pylon	25 ft. maximum height 100 sq. ft. maximum area	Sign not allowed	25 ft. maximum height 100 sq. ft. maximum area	Sign not allowed	Sign not allowed	Sign not allowed
Monument	4 ft. maximum height 36 sq. ft. maximum area	4 ft. maximum height 24 sq. ft. maximum area	4 ft. maximum height 36 sq. ft. maximum area	4 ft. maximum height 24 sq. ft. maximum area	Sign not allowed	Sign not allowed
Attached						
Projecting	25 ft. maximum height 100 sq. ft. maximum area 8 ft. minimum clearance from underlying walkway or thoroughfare	Sign not allowed	25 ft. maximum height 100 sq. ft. maximum area 8 ft. minimum clearance from underlying walkway or thoroughfare	Sign not allowed	Sign not allowed	Sign not allowed
Roof	1:2 (bldg. frontage to sign area ratio) 50 sq. ft. maximum area	Sign not allowed	Sign not allowed	Sign not allowed	1:2 (bldg. frontage to sign area ratio) 50 sq. ft. maximum area	Sign not allowed
Wall	1:2 (bldg. frontage to sign area ratio) 50 sq. ft. maximum area	1:2 (bldg. frontage to sign area ratio) 50 sq. ft. maximum area	Sign not allowed	1:2 (bldg. frontage to sign area ratio) 50 sq. ft. maximum area	1:2 (bldg. frontage to sign area ratio) 50 sq. ft. maximum area	1:2 (bldg. frontage to sign area ratio) 50 sq. ft. maximum area
Total area sq. ft.	150	150	100	100	50	50
Total number	1 Freestanding 2 Attached per frontage	1 Freestanding 2 Attached per frontage	1 per frontage	1 per frontage	1	1

No monument signs shall be permitted on the Mane Street side of structures.

11. TEMPORARY USES

Temporary Special Events shall be permitted within the district as follows:

Types

- i. Class 1 Major Events. No Class 1 Major Events shall be permitted within the district.
- ii. Class 1 Minor Event. No more than four Class 1 Minor Events shall be permitted within the district in any 12 month period.
- iii. Class 2 Major Event. No Class 1 Minor Events shall be permitted within the district.
- iv. Class 2 Minor Event. No more than two Class 2 Minor Events (200-500 persons) shall be permitted within the district in any twelve month period.
- v. Class 2 Minor Event (less than 200 persons). No limit.

Commentary: There has been increasing interest in holding events and festivals on Mane Street and demand for these types of activities is expected to continue to increase. In recognition of Mane Street's location within a larger residential community, its remoteness from emergency services, and based on Pioneertown's limited circulation and parking infrastructure, limits on the quantity of events are warranted. Pappy and Harriet's is the only venue with a legal capacity of 1,000 persons or more, and full capacity events held at that location have a significant impact on the surrounding community (traffic, parking) which has influenced the proposed thresholds above.

For context, San Bernardino County defines Temporary Special Events as several categories based on size, intensity, and likelihood of impact on the surrounding community. The Development Code allows events to be held in any location at the discretion of staff, but are evaluated based on their size, scale and impact based on definitions in the Development Code which are included here to clarify the terminology:

(1) Minor Event

(A) CLASS I. Anticipated attendance of 500 to 1,000 persons per day; or a community celebration, religious festivals, revival meetings, food truck events and similar public gatherings with anticipated attendance of 500 or more. Staging events of off-highway motor vehicles, as defined and regulated in Chapter 4 of Division 8 of Title 2, shall also be included as a CLASS I MINOR EVENT.

Commentary: Class 1 Minor events include festivals and events that have the potential for significant impact on the community but are probably acceptable if limited in quantity.

(B) CLASS II. Intensive sporting events, such as off-road vehicle races or rodeos, etc., and music events with an anticipated attendance of 200 to 500 persons per day. Included in this class are any events that are advertised by a means of mass media (i.e., radio, television, newspaper, Internet, phone trees, fliers, etc.) provided that a means of limiting attendees to 500 persons per day is available and is strictly enforced.

Commentary: Class 2 Minor events include festivals and events that have the potential for significant impact on the community but are probably acceptable if limited in quantity.

(2) Major Event

(A) **CLASS I.** Anticipated attendance of over 1,000 persons per day.

Commentary: Class 1 Major events include large festivals and events that are not compatible with Pioneertown's surrounding rural residential setting.

(B) **CLASS II.** Intensive sporting events, such as off-road vehicle races or rodeos, etc., or music events with an anticipated attendance of over 500 persons per day. Included in this class are any events that are advertised by a means of mass media (i.e., radio, television, newspaper, Internet, phone trees, fliers, etc.) where a means of limiting attendees is not available.

Commentary: Class 2 Major events are intensive and will provide community impact by definition, and are not compatible with Pioneertown's surrounding residential areas.

Parking

For any Temporary Special Event attended by more than 500 persons, event parking shall be provided outside of the district boundary with an approved shuttle or transportation plan.

Commentary: There has been increasing interest in holding events and festivals on Mane Street and the demand for these types of activities is expected to continue to increase. In recognition of Mane Street's location within a larger residential community, and based on Pioneertown's limited circulation and parking infrastructure, limits on the quantity of events are warranted. Limited capacity for parking exists within the Mane Street district boundary; this requirement acknowledges physical limitations associated with additional cars within the district, as well as the potential for conflict with pedestrians and horses.

12. PROPOSED LAND USE TABLE

The Use Tables are part of the San Bernardino County Development Code that outline allowable uses and prescribe the type of review or approval that is required for each use by zone. The current Use tables and zoning for Pioneertown make no distinction between the Mane Street and its surrounding residential areas, nor do they recognize Mane Street's commercial history.

The revised Use tables proposed here are intended to:

1. Simplify approvals for the small-scale commercial Uses that are historic to Pioneertown and are part of its attraction.
2. Encourage small-scale development that is more likely to be created by owner-operators and local entrepreneurs.
3. Encourage reuse, restoration, and reuse of historic buildings.
4. Balance businesses aimed at tourists with those of the local community.
5. Mitigate or prevent negative impact from incompatible uses and large-scale development.

The proposed table also relies heavily on the concept that size and scale are directly related to character and impact, and that Pioneertown's character and draw to tourists comes largely from the diversity of experience and direct connections with business owners that are local to and personally invested in the community.

Table 5 - Allowed Land Uses

Allowed Land Uses and Permit Requirements for Pioneertown Mane Street Historic Overlay (PMSHO) District				
	SD-RES (Current)	PMSHO (Proposed)	Change from Existing to PMHSO - Harder or Easier?	Commentary
AGRICULTURE, RESOURCE & OPEN SPACE USES				
Agriculture support services	M/C	—	Harder	These uses are incompatible (animal waste processing, impement dealerships, etc)
Animal Keeping	S	S	No Change	
Crop production, horticulture, orchard, vineyard	A	A	No Change	
Natural resources development (mining)	CUP	—	Harder	This use is incompatible
Nature preserve (accessory uses)	P	P	No Change	
INDUSTRY, MANUFACTURING & PROCESSING, WHOLESALING				
Construction contractor storage yard	M/C	—	Harder	This use is incompatible
Firewood contractor	—	—	No Change	
Manufacturing Operations I	CUP	—	Harder	This use is incompatible
Motor vehicle storage/Impound facility	—	—	No Change	
Recycling facilities - Small collection facility	—	—	No Change	
Recycling facilities - Large collection facility	—	—	No Change	
Recycling facilities - Light processing facility	—	—	No Change	
Recycling facilities, reverse vending machine (accessory only)	A	A	No Change	
Salvage operations - within enclosed structures	—	—	No Change	

Storage - Personal storage (mini-storage)	M/C	—	Harder	This use is incompatible
Storage - Recreational vehicles	M/C	—	Harder	This use is incompatible
Storage - Warehouse, Indoor Storage	—	—	No Change	
Wholesaling and distribution	—	—	No Change	
RECREATION, EDUCATION & PUBLIC ASSEMBLY				
Adult business	—	—		
Campgrounds	CUP	CUP/SP*	No Change, easier for historic structures	For shelter provided by guests*
Commercial entertainment – Indoor, under 3,000 SF	M/C	CUP/SP*	Harder, easier for historic structures	This includes arcades, ballrooms, arcades, ice and rolling skating rinks
Commercial entertainment – Indoor, 3,000 - 5,000SF	M/C	— / MUP*	Harder, easier for historic structures	This includes arcades, ballrooms, arcades, ice and rolling skating rinks
Commercial entertainment – Indoor, larger than 5,000 SF	M/C	— / CUP*	Harder, easier for historic structures	This includes arcades, ballrooms, arcades, ice and rolling skating rinks
Commercial entertainment - Outdoor	—	—	No Change	This includes skate parks, water slides, mini-golf, driving ranges and theme parks.
Conference/convention facility (4, 5)	CUP	—	Harder	
Equestrian facility	M/C	SP	Easier	Equestrian uses are encouraged by the Community Action Guide
Fitness/health facility (5)	M/C	M/C/SP*	No Change	
Golf course	CUP	—	Harder	A golf course could not be physically accomodated within the district.
Library, museum, art gallery, outdoor exhibit	M/C	M/C/SP*	No Change, easier for historic structures	
Meeting facility, public or private (5), under 2,000 SF	CUP	CUP/MUP*	No Change, easier for historic structures	
Meeting facility, public or private (5), 2,000 SF to 2,999 SF	CUP	CUP	No Change	
Meeting facility, public or private (5), 3,000 SF or greater	CUP	—	Harder	
Park, playground	P	SP	Harder	

Places of worship	CUP	M/C/SP*	Easier	
Recreational vehicle park	—	—	No Change	
Rural sports and recreation	CUP	—	Harder	Incompatible. Includes rifle and archery ranges, ski resorts, etc.
School - College or university, under 3,000 SF (5)	M/C	CUP/SP*	Harder, easier for historic structures	
School - College or university, 3,000 SF or larger (5)	M/C	— / MUP*		
School - Private under 3,000 SF(5)	M/C	CUP/SP*	Harder, easier for historic structures	
School - Private 3,000 SF or larger (5)	M/C	— / MUP*		
School - Specialized education/ training, under 3,000SF (5)	M/C	CUP/SP*	Harder, easier for historic structures	
School - Specialized education/ training, 3,000SF or larger (5)	M/C	— / MUP*		
Sports or entertainment assembly	—	—	No Change	
Theater (5), less than 3,000SF	—	CUP/SP*	Easier	Includes movie and dramatic theaters
Theater (5), 3,000SF or larger	—	—	No Change	
RESIDENTIAL				
Accessory dwelling (caretakers residence, etc.)	P	SP	Harder	
Accessory use or structure - Residential (conforming and nonconforming uses)	P	SP	Harder	
Group residential (sorority, fraternity, boarding house, private residential club, etc.)	M/C	—	Harder	
Guest housing	P	SP	Harder	
Live/work unit	M/C	MUP/SP*	Easier	Live/work is a compatible use.
Mobile home park/manufactured home land-lease community	CUP	—	Harder	

Multiple dwelling, up to 19 units, attached or detached	—	—	No Change	
Multiple dwelling, 20 or more units	—	—	No Change	
Multiple residential use	PD	—	Harder	
Parolee and/or probationer home	CUP	—	Harder	
Residential use only as part of a mixed use project	PD	PD	No Change	
Accessory dwelling unit	A	SP	Harder	
Single dwelling	A	SP/A*	Harder	
RETAIL				
Auto and vehicle sales and rental	M/C	—	Harder	
Bar, tavern, under 2,000 SF	M/C	MUP/SP*	Harder, easier for historic structures	
Bar, tavern, 2,000-2,999 SF	M/C	CUP/MUP*	Harder, easier for historic structures	
Bar, tavern, 3,000 SF or larger	M/C	— / CUP*	Harder	
Building and landscape materials sales - Indoor	M/C	—	Harder	
Building and landscape materials sales - Outdoor	—	—	No Change	
Construction and heavy equipment sales and rental	—	—	No Change	
Convenience store, less than 3,000 SF	M/C	MUP/SP*	Easier	
Farmers Market, 10 or less vendors	—	MUP/SP*	Easier	Serves tourism and local interests, does not require construction
Farmers Market, 11 to 20 vendors	—	CUP/MUP*		
Fuel dealer (propane for home and farm use, etc.)	CUP	—	Harder	
General retail, under 2,000SF	M/C	MUP/SP*	Easier	
General retail, 2,001 to 5,000SF	M/C	CUP/MUP*	Harder	
General retail, more than 5,000 SF	PD	— / CUP*	Harder	

Groceries, specialty foods, less than 2,000 SF	—	CUP/MUP*	Easier	
Groceries, specialty foods, 2,000 SF or greater	—	— / CUP*		
Manufactured home, boat, or RV sales	—	—	No Change	
Night club	M/C	—	Harder	Night club uses represent a significant likelihood of neighborhood nuisance
Outdoor Dining	M/C	SP*	Easier	Subject to limitations on size and hours of operation
Restaurant, café, coffee shop, 1,500 SF or Less	M/C	MUP/SP*	Harder, easier for historic structures	
Restaurant, café, coffee shop, 1,501SF - 3,000SF	M/C	CUP/MUP*	Harder, easier for historic structures	
Restaurant, café, coffee shop, Greater than 3,001 SF	M/C	— / CUP*		
Service station	M/C	—	Harder	
Second hand stores, pawnshops	M/C	MUP/SP*	Easier	
Shopping center	—	—	No Change	
Swap meet, outdoor market, auction yard, under 2,000 SF	—	CUP/MUP*	Easier	
Swap meet, outdoor market, auction yard, 2,000 SF or greater	—	— / CUP*	Easier	
Warehouse retail	—	—	No Change	
SERVICES - BUSINESS, FINANCIAL, PROFESSIONAL				
Medical services - Hospital	M/C	—	Harder	
Medical services - Rehabilitation center	M/C	—	Harder	
Office - Accessory	P	P	No Change	
Professional services, less than 2,000 SF	M/C	MUP/SP*	Easier	
Professional services, 2,000 SF or greater	M/C	CUP/MUP*		

SERVICES - GENERAL				
Bail bond service within 1 mile of correctional institution	—	—	No Change	
Cemetery including pet cemeteries	CUP	—	Harder	
Child care - Day care center	—	CUP/SP*	Easier	
Convenience and support services	—	CUP/SP*	Easier	
Emergency shelter	CUP	—	Harder	
Equipment rental	—	—	No Change	
Formula Business		—	Harder	Formula and chain businesses are not restricted by the current development code
Home occupation	SUP	SUP	No Change	
Kennel or cattery - 2.5-acre minimum lot area	M/C	—	Harder	
Licensed Residential Care Facility of 6 or fewer persons	M/C	—	Harder	
Licensed Residential Care Facility of 7 or more persons	M/C	—	Harder	
Lodging - Bed and breakfast inn (B&B)	SUP	M/C/SP*	Harder	
Lodging - Hotel or motel - 5 or fewer guest rooms	M/C	MUP/SP*		
Lodging - Hotel or motel - 6 to 10 guest rooms	M/C	CUP/MUP*	Harder	
Lodging - Hotel or motel - More than 10 guest rooms	M/C	—/CUP*	Harder	
Personal services	M/C	M/C/SP*	No Change, easier for historic structures	
Public restroom facility	—	SP	Easier	No provision for this Use exists under the current code.
Public safety facility	M/C	CUP/SP*	Harder, easier for historic structures	
Unlicensed Residential Care Facility of 6 or fewer persons	M/C	—	Harder	

Unlicensed Residential Care Facility of 7 or more persons	—	—	No Change	
Vehicle services - Major repair/body work	—	—	No Change	
Vehicle services - Minor maintenance/repair	—	—	No Change	
Veterinary clinic, animal hospital	—	—	No Change	
TRANSPORTATION, COMMUNICATIONS & INFRASTRUCTURE				
Ambulance, taxi, or limousine dispatch facility	M/C	—	Harder	
Broadcasting antennae and towers	CUP	—	Harder	
Broadcasting studio	CUP	—	Harder	
Parking lots and structures, accessory	M/C	SP	Easier	
Pipelines, transmission lines, and control stations (9)	—	—	No Change	
Renewable Energy Generation Facilities	—	—	No Change	
Sewage treatment and disposal facility	—	—	No Change	
Solid waste disposal	—	—	No Change	
Transportation facility	M/C	—	Harder	
Truck Stop	—	—	No Change	
Truck Terminal	—	—	No Change	
Utility facility	CUP	—	Harder	
Wind energy system, accessory	S	—	Harder	
Wireless telecommunications facility	S	CUP	Harder	
OTHER				
Accessory structures and uses	P	—	Harder	
Off-Site Signs	—	—	No Change	
Off-Site Signs (Freeway Oriented)	—	—	No Change	

Temporary special events	TSP	TSP	No Change	
Temporary uses and activities	TSP	TSP	No Change	

Note:
 *Lower review requirement for uses entirely contained within structures noted as Contributing under the Mane Street Historic District National Register listing
 (2) CUP required if maximum building coverage exceeds 10,000 SF, the use will have more than 20 employees per shift, or if not exempt from CEQA, may qualify for a MUP in compliance with SS 85.06.020 (Applicability)
 (6) Use allowed as an accessory use only, on the same site as a retail, service, or industrial use allowed by this table
 (7) Use allowed as an accessory use only, on the same site as a residential use allowed by this table
 Other citations refer to footnotes found in the Development Code SD-RES Use Table.

DRAFT

LMA

LOESCHER MEACHEM ARCHITECTS

353 S. Broadway, Suite 201 Los Angeles, CA 90013

t: 213.948.2888

www.lma.la